

# FOOD CONTAINER, MODEL GB-7 L OPERATION & MAINTENANCE SHEET

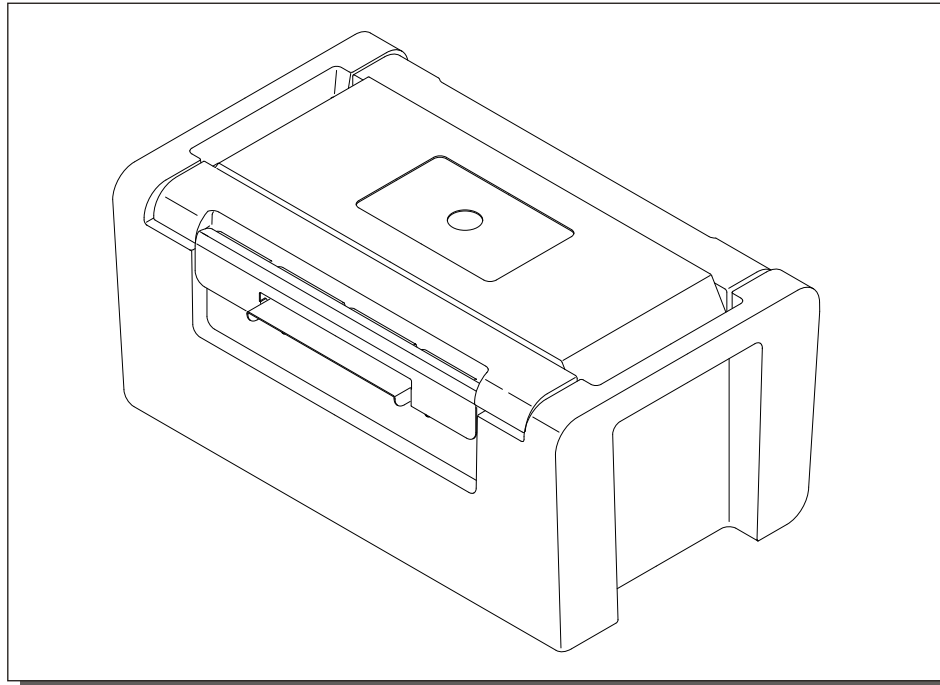

## Procedures for Optimum Temperature Holding & Performance

Preheating of the container is unnecessary; however, for optimum performance the following steps are recommended.

- Fill the stainless steel container with hot water (max. 90°C) 30 minutes prior to inserting desired HOT food. For cold food chill the stainless steel container in a refrigerator, freezer, or by filling with chilled water.
- Place the desired food inside the stainless steel liner and fill till the liner is full.
- Secure the inner & outer lid to the container as quickly as possible.
- Using the provided labels, mark the contents of each container.
- Non-prepackaged (processed) food must be stored in Gastronorm-containers with sealed lid.

## Care & Cleaning

- Clean the containers (stainless steel and plastic) after each use by using a neutral detergent.
- Remove gasket for cleaning regularly. Clean gasket with a neutral detergent and a thin barrel brush.
- Container may be run through a dishwasher with temperature up to 90°C with no adverse effects to the components. Remove gasket from outer lid before washing in a dishwasher.
- Allow unit to air dry after cleaning and reassemble unit.

# FOOD CONTAINER, MODEL GB-7 L

## REPLACEMENT PARTS LIST

Occasionally parts will wear out or become lost.

Accordingly, replacement parts are available from the Sint-Plast USA Distributor:

K.C. Trading, Ltd., Cage code: 1P9K9

Phone: 540-720-8400 / Fax: 540-720-7077 / Email: kctrading@aol.com

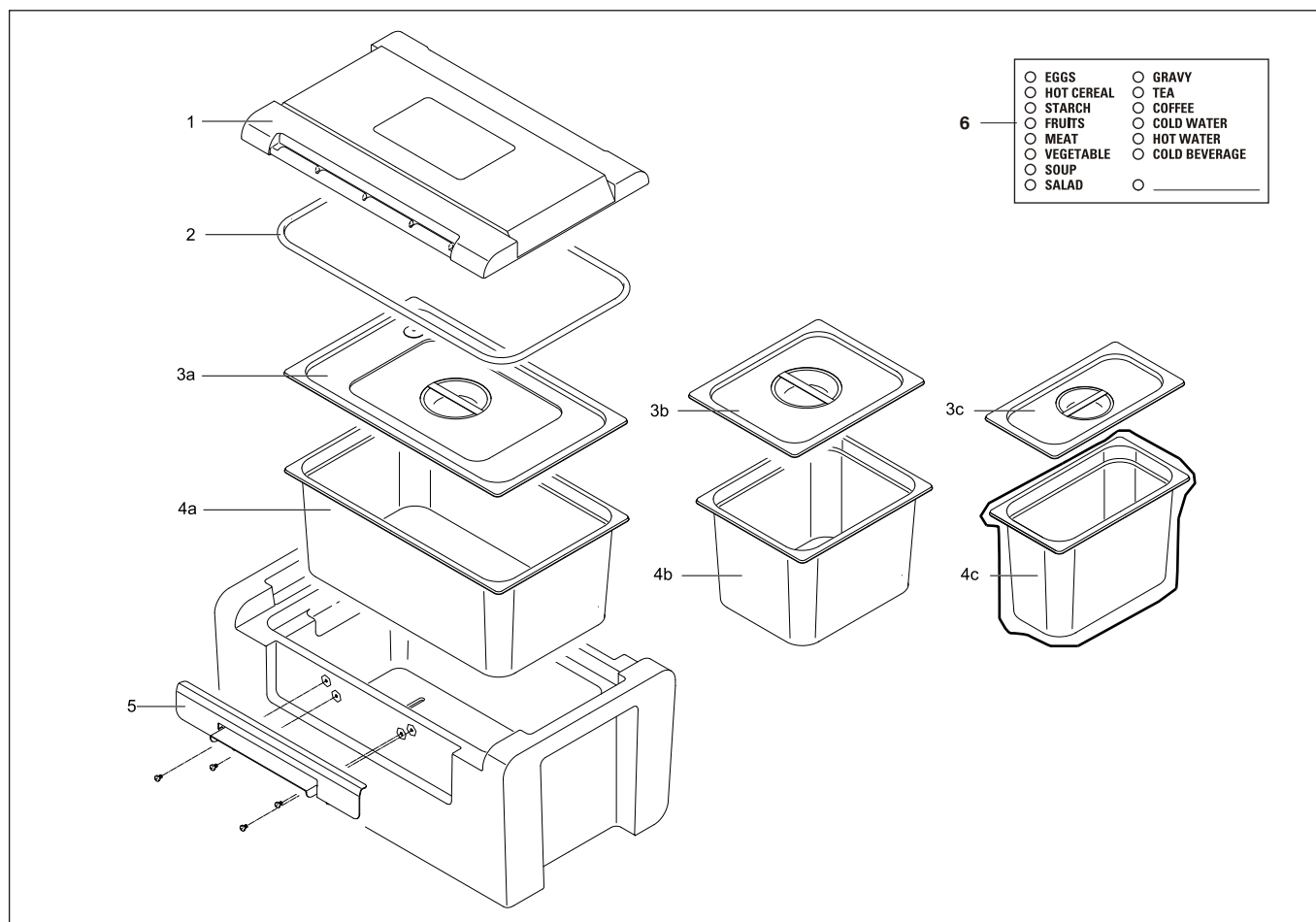

### List of Components

FIG-KEY	STOCK NUMBER	ITEM IDENTIFICATION	U/I	QTY
1	296.1230.00	Lid, Outer, NATO-green	EA	1
	296.1230.01	Lid, Outer, blue	EA	1
	296.1230.02	Lid, Outer, sand-yellow	EA	1
	296.1230.03	Lid, Outer, turquoise-green	EA	1
2	294.5101.20	Gasket, Seal, Outer Lid	EA	1
3a	296.1407.20	Lid GN1/1, Stainless Steel, With Gasket	EA	1
3b	296.1407.20	Lid GN1/2, Stainless Steel, With Gasket	EA	2
3c	296.1407.20	Lid GN1/3, Stainless Steel, With Gasket	EA	3
4a	296.1405.10	Container GN 1/1, Stainless Steel	EA	1
4b	296.1405.10	Container GN 1/2, Stainless Steel	EA	2
4c	296.1405.10	Container GN 1/3, Stainless Steel	EA	3
5	296.3349.20	Clamp, Pullover, Stainless Steel	EA	2
6	294.5203.02	Label, Self Adhesive, Roll, 250 Labels	RO	1
	820.9503.45	Operation Manual GB-7 L	EA	1

**Domet'c** s.à.r.l.

op der Hei, 17  
L - 9809 Hosingen  
LUXEMBOURG

phone +352 920731 1  
fax +352 920731 300  
email sintplast@dometic.lu



K.C Trading, Ltd.  
Mr. Charles Velez  
phone: +1 540 720 8400  
fax: +1 540 720 7077  
email: kctrading@aol.com